



P1 Companion Standard

Dutch Smart Meter Requirements

By order of: **Enbin**
Reference: **B1041**
Date: **April 18th, 2008**
Version: **2.2**
Status: **Final**



Change Summary

Revision	Created / Modified	Date	Approved	Comment
2.1	H. Pille	04-Feb-08	Steering group	Final version
2.2	H. Pille	04-Apr-08	Steering group	1.4.5: max current changed from 5 to 30 mA
2.2	H. Pille	04-Apr-08	Steering group	OBIS codes added for thermal and water meters
2.2	H. Pille	18-Apr-08	Steering group	Meter identifier replaced by equipment identifier
2.2	H. Pille	18-Apr-08	Steering group	References to use cases updated

**Issue list**

Version	Activity
2.1	Technical appendix in NTA8130 is not included in this document. Reconsider to copy this information in the P1 CS.



Contents

1	Introduction	5
1.1	Scope	5
2	System architecture	6
3	Normative references	7
4	Physical Interface Characteristics	8
4.1	Galvanic Isolation	8
4.2	Connection	8
4.3	Addressing the measuring device	8
4.4	Measuring device response time	9
4.5	Signals	9
4.6	Physical connector	9
5	Protocol Description	10
5.1	Transfer speed	10
5.2	Data readout	10
5.3	End of transmission	10
6	Data objects	11
6.1	Electricity data	11
6.2	Messages	11
6.3	Gas Data	12
6.4	Thermal Data	13
6.5	Water Data	13
7	Document list	14

1 INTRODUCTION

1.1 Scope

This document provides a companion standard for an Automatic Meter Reading (AMR) system for electricity thermal, (heat & cold), gas, water and hot water meters. The scope of this standard is on:

- Residential electricity meters
- Residential thermal (heat & cold) meters
- Residential gas meters and gas valve
- Residential water meters

This companion standard focuses on the P1 interface for gas, gas valve, thermal (heat / cold), and water meters. There is no separate interface for electricity meters since these meters are technically part of the metering system.

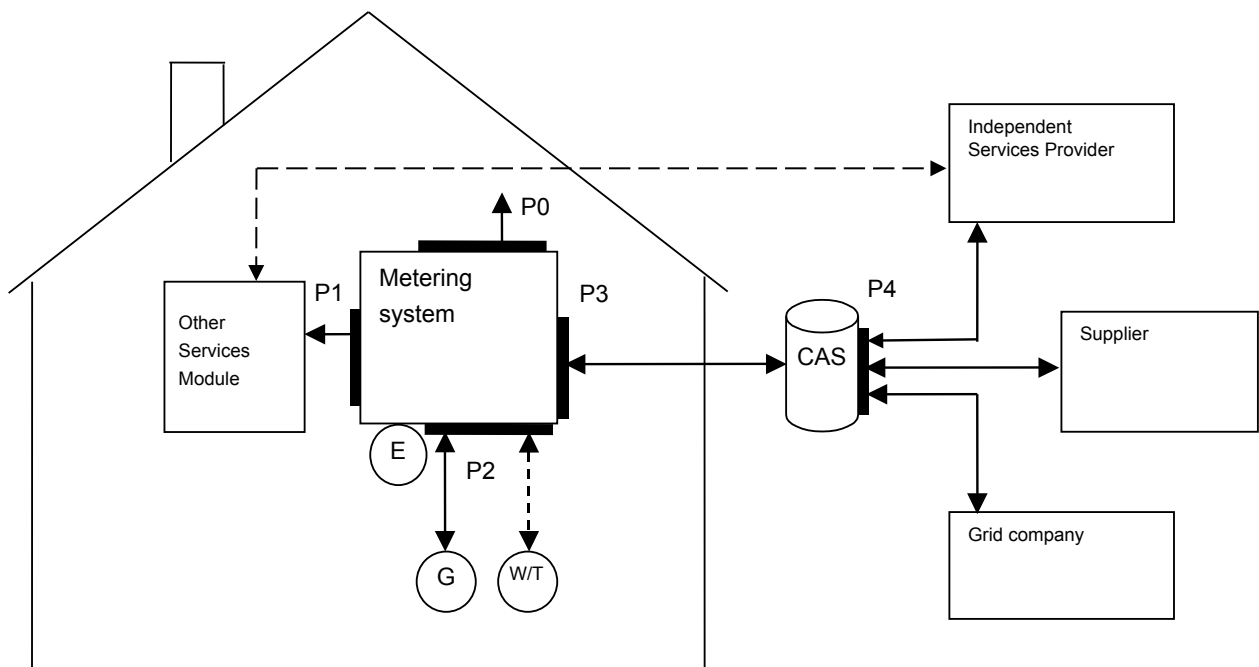

Figure 1. : Meter interfaces overview.

The goal of this companion standard is to reach an open, standardized protocol implementation and functional hardware requirements related to the communication between several types of Service Modules and a Metering System. Any specification in this standard is intended to encourage suppliers to develop their hardware and software in a common direction. Standardised protocols and hardware specifications are referred to as much as possible.

This companion standard is the result of a combined effort of the major Dutch grid operators.



2 SYSTEM ARCHITECTURE

The interface is based on the following:

- Simple installation by customer;
- Simple and clearly defined interface;
- Low cost for the installation itself;
- Low cost for the customer installing, operating and maintaining the interface;
- Safe for the customer;
- The metering system or the data in it cannot be compromised.

The interface is based on NEN-EN-IEC 62056-21 (Electrical metering-Data exchange for meter reading, tariff and load control – Part 21: direct local data exchange, 2002-05). Functional and technical requirements are given in the NTA 8130 document (see section 3). This companion standard holds physical characteristics and protocol definitions for the interface.



3 NORMATIVE REFERENCES

The following standards are referred to in this company standard. For undated references the latest edition applies.

NEN-EN-IEC 62056-21:2002	Electricity metering Data exchange for meter reading, tariff and load control Part 21: Direct local data exchange
NEN-EN-IEC 62056- 61:2002	Electricity metering – Data exchange for meter reading, tariff and load control – Part 61: OBIS Object Identification System
NTA 8130 NL:2007	<i>Basisfuncties voor de meetinrichting voor elektriciteit, gas en thermische energie voor kleinverbruikers</i>

4 PHYSICAL INTERFACE CHARACTERISTICS

4.1 Galvanic Isolation

To protect the Metering System and to lower the possibility of influencing the Metering System through the P1 port, the P1 port will be equipped with an opto-coupler. The opto-coupler must be installed in the Metering System. The opto-couplers must adhere to the relevant legislation and standards for measuring equipment. The interface must be protected against reversed connection and necessary over-voltage protection.

4.2 Connection

Standardised connections are not readily available or are not suitable for this port. To ensure a safe, stable solution the connection will consist of three wires: one request signal, one data signal and signal ground. Activating the port is by activating (raising) the request signal (~5V). While receiving data the requesting Service Module will keep the request port activated (raised).

More than one system may be connected to the measuring device, each system may request data input and all systems will receive the same data sent by the measuring device.

4.3 Addressing the measuring device

Since a measuring device will have no more than one P1 port, there is no need to address it. It should be possible to connect more than one device with OSM (Other Service Module) activated or not. Dropping the request line by connecting to ground is not allowed, to prevent short circuit.

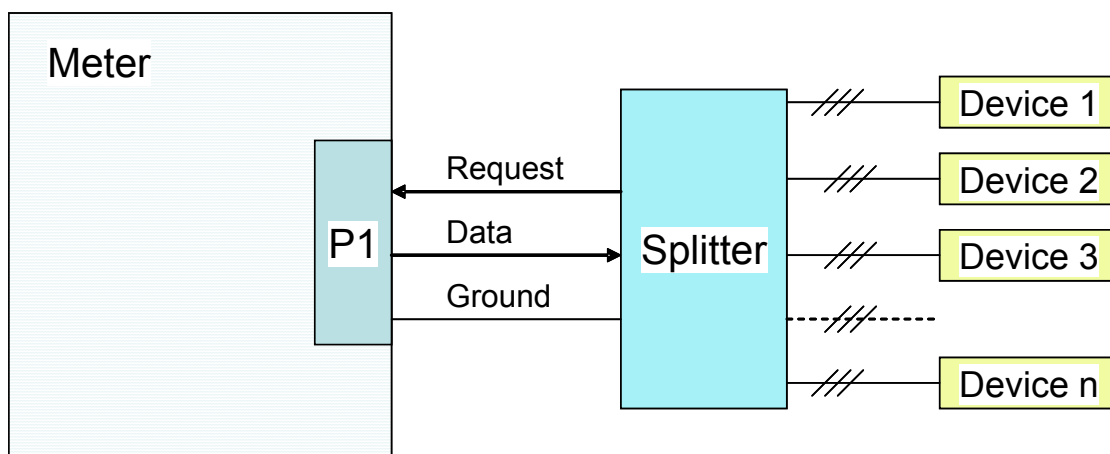

Figure 2.
:

Diagram for connecting more than one device to P1 port.

Modulating the request signal is not allowed. Data transfer will stop immediately after the request signal is dropped.

Note: the electrical interface is not conforming to EN-IEC 62056-21 Mode D.



4.4 Measuring device response time

The measuring device must complete a data transfer within eight seconds.

4.5 Signals

All signals are compliant with CMOS levels.

Max current $I_H(\text{max}) = 30\text{mA}$

4.6 Physical connector

The connector is RJ11. The Metering System holds a female connector, the customer can plug in a standard RJ11 plug. Note that the connector in the metering system is physically accessible at all times and should not be sealed or protected by a sealed cover.

Pin #	Signal name	Description
1		
2	Request	Input
3	GND	Ground
4	N.C.	Not Connected
5	Data	Output
6		



5 PROTOCOL DESCRIPTION

The protocol is based on NEN-EN-IEC 62056-21 Mode D. Data transfer is read-only in that the customer's Service Module cannot send data or acknowledge receiving data to the Metering System. The Mode D transfer is usually initiated by a push button. Note that the P1 interface does not support push buttons. Raising the request line on the interface results in transfer initiation.

5.1 Transfer speed

The interface will use a fixed transfer speed of 9600 bps. There are no options to switch the transmission speed. Note this is not conforming to EN-IEC 62056-21 Mode D.

5.2 Data readout

The Metering System transmits the data message immediately following the activation through the Request signal. A series of blocks containing the following are sent:

/	X	X	X	3	Identification	CR	LF	CR	LF	Data	!	CR	LF
---	---	---	---	---	----------------	----	----	----	----	------	---	----	----

5.3 End of transmission

The data transmission is complete after the data message has been transmitted by the Metering System. An acknowledgement signal is not provided for.



6 DATA OBJECTS

Data Objects are defined in NEN-EN-IEC 62056-61:2002 Electricity metering – Data exchange for meter reading, tariff and load control – Part 61: OBIS Object Identification System. The following tables hold data objects and references to the OBIS. Note that this table assumes two tariffs. Currently two tariffs (Rate 1 and Rate 2) are defined, support for up to four tariffs should be included.

6.1 Electricity data

Electricity – transfer every ten seconds

Value	OBIS reference	NTA Use Case reference
Equipment identifier	0-0:42.0.0.255	Use case 3: Provide actual meter reads through P1 Use case 5: Provide equipment status to P1
Meter Reading electricity delivered to client normal tariff) in 0,01 kWh	1-0:1.8.1.255	Use case 3: Provide actual meter reads through P1
Meter Reading electricity delivered to client (low tariff) in 0,01 kWh	1-0:1.8.2.255	Use case 3: Provide actual meter reads through P1
Meter Reading electricity delivered by client (normal tariff) in 0,01 kWh	1-0:2.8.1.255	Use case 3: Provide actual meter reads through P1
Meter Reading electricity delivered by client (low tariff) in 0,01 kWh	1-0:2.8.2.255	Use case 3: Provide actual meter reads through P1
Tariff indicator electricity. The tariff indicator can be used to switch tariff dependent loads e.g boilers. This is responsibility of the P1 user	0-0:96.14.0.255	Use case 5: Provide equipment status to P1
Actual electricity power in 1 Watt resolution	1-0:1.7.0.255	Use case 3: Provide actual meter reads through P1
The actual threshold Electricity in A	0-0:17.0.0.255	Use case 5: Provide equipment status to P1
Actual switch position Electricity (in/out).	0-0:24.4.0.255	Use case 5: Provide equipment status to P1

Note: Tariff code 1 is used for low tariff and tariff code 2 is used for normal tariff.

6.2 Messages

Text messages, transfer every ten seconds

Value	OBIS reference	NTA Use Case reference
Text message codes: numeric 8 digits	0-0:96.13.1.255	Use case 12: Display standard messages on meter display and P1



Value	OBIS reference	NTA Use Case reference
Text message max 1024 characters.	0-0:96.13.0.255	Use case 13: Sending long messages to port P1

The Meter will have storage capacity for one numeric message code and one 1024 character text message. Message codes and text messages are handled independently, but in the same way.

If a device is connected, the meter will send the message (code and/or text) over the P1 interface every ten seconds. The text messages may not contain the control character sequence <cr><lf> (ASCII codes 0Dh 0Ah).

6.3 Gas Data

The following only if Gas meters are connected.

Gas – Transfer every ten seconds, the latest received hourly values & timestamps

Value	OBIS reference	NTA Use Case reference
Equipment identifier	7-0:0.0.0.255	Use case 3: Provide actual meter reads through P1
24 hourly meter readings over the period previous to the transmission, gas delivered to client in 0,001 m3 each value incl. date and time.	7-0:23.1.0.255	Use case 3: Provide actual meter reads through P1
24 hourly meter readings temperature compensated gas over the period previous to the transmission, gas delivered to client in 0,001 m3 each value incl. date and time.	7-0:23.2.0.255	Use case 3: Provide actual meter reads through P1
Valve position gas (on/off/released).	7-0:24.4.0.255	Use case 5: Provide equipment status to P1

Note: Only one of the two Gas Meter Readings (temperature compensated or not) will be used.



6.4 Thermal Data

The following only if Thermal (H/C) meters are connected.

Thermal (H/C)– Transfer every ten seconds, the latest received hourly values & timestamps

Value	OBIS reference	NTA Use Case reference
Equipment identifier	x-0:0.0.0.255	Use case 3: Provide actual meter reads through P1 (x=5:Heat; x=6: Cooling)
Meter reading Heat in 0,01 GJ	5-0:1.0.0.255	Use case 3: Provide actual meter reads through P1
Meter reading Cold in 0,01 GJ	6-0:1.0.0.255	Use case 3: Provide actual meter reads through P1

6.5 Water Data

The following only if water meters are connected.

Water –Transfer every ten seconds, the latest received hourly values & timestamps

Value	OBIS reference	NTA Use Case reference
Equipment identifier	8-0:0.0.0.255	Use case 3: Provide actual meter reads through P1
Meter reading in 0,001 m3	8 -0:1.0.0.255	Use case 3: Provide actual meter reads through P1



7 DOCUMENT LIST

Following table shows the complete set of documents that build up the Dutch Smart Meter Requirements, of which this Companion standard P1 document is a part of.

#	Document name postfix	description
[1]	main	The main document of the Dutch Smart Meter Requirements, containing all definitions and most of the use cases and requirements
[2]	tender	Tender document, containing additional general requirements, use cases and performance requirements
[3]	P1	Companion standard P1
[4]	P2	Companion standard P2
[5]	P3	Companion standard P3